

Ride Forged Clips **SS**
Bridas Forjadas



Ride Forged Clips SS

Bridas Forjadas



Bridas forjadas
Forged Clips

Bridas Forjadas

Forjadas en caliente, amarran la guía ejerciendo gran presión sobre ella. Se recomienda su utilización en edificios de poca altura, pues podrían producirse torceduras en la guía por pandeo y daños en las fijaciones a la pared, debido a la compresión del edificio y a las variaciones de temperatura.

Forged Clips

Hot forged clips that hold the guide rail down by exerting great pressure on it.

Their use is recommended in buildings that are not very high as curves due to buckling might appear in the guide rail and damage the brackets or the wall anchorages, as result of the compression of the building and the variations in temperature.

Aplicación / Application				
Recorrido Travel distance	Alto / High	✗	✗	✗
	Medio / Medium	✗	✗	✗
	Bajo / Short	✓	✓	✓
		Bajo / Low	Medio / Medium	Alto / High
Fuerzas laterales Fx / Lateral forces Fx				

		Par de apriete Tightening torque kgf-m				
		SS1	SS2	SS3	SS4	SS5
Calidad Property class	4.8	2,1	3,5	5,6	8,6	12
	5.8	2,5	4,4	6,9	10,5	14,5
	8.8	3,9	6,6	10,5	16	23

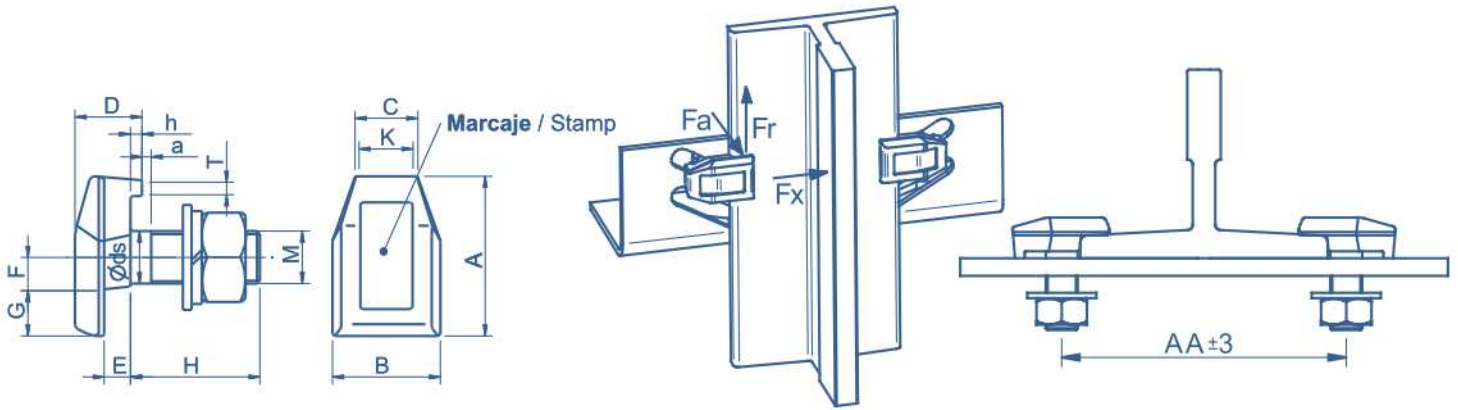

Bridas Forjadas / Forged Clips

Bridas Forjadas - Tipo SS Forged clips - Type SS

Tipo Type	Nº Pz. Caja No.Pc. Box	Peso Caja Box Weight kg	Aplicaciones Applications	A ±1,25 mm	B ±1,05 mm	C ±1,05 mm	D ±0,9 mm	E ±0,75 mm	F ±0,5 mm	G ±0,9 mm	H ±1,05 mm	h ±0,3 mm	K min.	T ≈	a max.	Øds ±0,7	M
SS1	500	33	T45/A, T50/A, T65/A	32	22	15	12	3,5	5	11	28	2	11	3	4	10	M10
SS2	400	33	T70/A, T75/A-B, T78/B, T82/A-B, T125-L1/A	39	26	19	15	4,3	6,5	13	32	3	15	3	5	12	M12
SS3	250	30	T70-70-9/A, T80-80-9/A, T89/A-B, T90/A-B	45	29	21	18,5	5,5	8	13	38	4	16	4	6	14	M14
SS4	200	36	T114/B, T125/B, T127-1/B	50	34	22	20,5	6,5	8,5	15	42	4	17	4	6	16	M16
SS5	100	32	T127-2/B, T140-1/B, T140-2/B	55	37	23	23	9	11	17	44	4	17,5	5	7	18	M18

Tipo de guía Type of guide		T45/A	T50/A	T65/A	T70/A	T70-70-9/A	T75/A-B	T78/B	T80-80-9/A	T82/A-B	T89/A-B	T90/A-B	T125-L1/A	T114/B	T125/B	T127-1/B	T127-2/B	T140-1/B	T140-2/B
Para fijar guías For fixing guide rails	F.Rozamiento / brida (kgf) Friction force / clip (kgf) Max.	170	170	170	260	350	260	260	350	260	400	400	350	500	500	500	700	700	700
Para fijar componentes For fixing components	F.Rozamiento / brida (kgf) Friction force / clip (kgf) Min.	120	120	120	180	250	180	180	250	180	300	300	250	320	320	320	500	500	500
Resistencia /Strength Max. Fa(kgf)		1900	1900	1900	2200	2600	2200	2200	2600	2200	2600	2600	2700	2950	2950	2950	2950	2950	2950
AA ±3 (mm)		55	60	75	83	86	88	91	96	95	105	106	138	131	142	144	148	161	161

Nota: Valores de fuerza de rozamiento y resistencia para brida de calidad 5.8. Para calidades 4.8 y 8.8 aplicar un factor corrector de 0.8 y 1.5 respectivamente. Las fuerzas de rozamiento (Fr) se han obtenido considerando sólo las bridas. Otros factores como montaje, material, acabado y deformación de los brackets pueden modificar estos valores.

Note: Values of friction force and strength for clip 5.8 class. Values shown in the table shall be multiplied by 0.8 and 1.5 for clip class 4.8 and 8.8 respectively. Friction forces (Fr) have been obtained considering only the clips. Other factors, such as clip assembly, bracket material and finishing and bracket deformations can modify these values.

NORMA Standard	Calidad Property class	Tuerca Hexagonal Hexagon Nut UNE EN ISO 4032	Resistencia Tensile strength N/mm ²	Composición Química Chemical Composition					
				Dureza Brinell HB Brinell Hardness HB		C%	B% max.	P% max.	S% max.
ISO 898-1	4.8	6	420 min.	124 - 209		0,55 max.	-	0,05	0,06
	5.8	6	520 min.	152 - 209		0,55 max.	-	0,05	0,06
	8.8	8	800 min.	d16 ≤ (245-316)	d16 > (250-331)	0,15-0,40	0,003	0,025	0,025

Arandela Grower / Spring washer : DIN 127

Arandela plana / Flat washer : UNE EN 28738

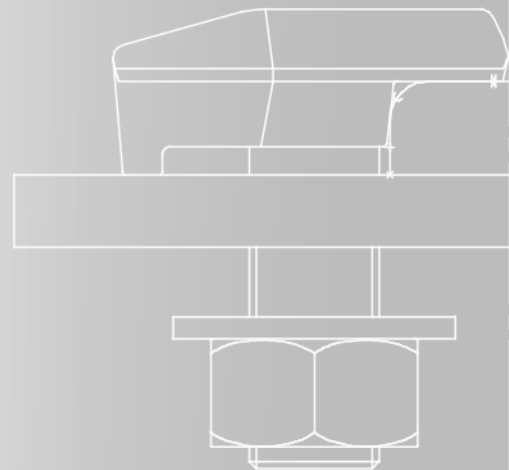

Ride Forged Clips **SS**

Bridas Forjadas

Rev. 01/13
Actualización vigente disponible en: www.saveragroup.com
Current updates available on: www.saveragroup.com

Fecha: 29.01.13
Preparado: J.Sanz
Revisado : I.Aristizabal
Aprobado : JV.Espín

B° de Zalain 31780 Bera - Navarra - Spain
Tel. +34 948 626 900 - Fax +34 948 626 904
savera@saveragroup.com

 **Savera**

Elevator System Solutions